

CABLE ROUTING

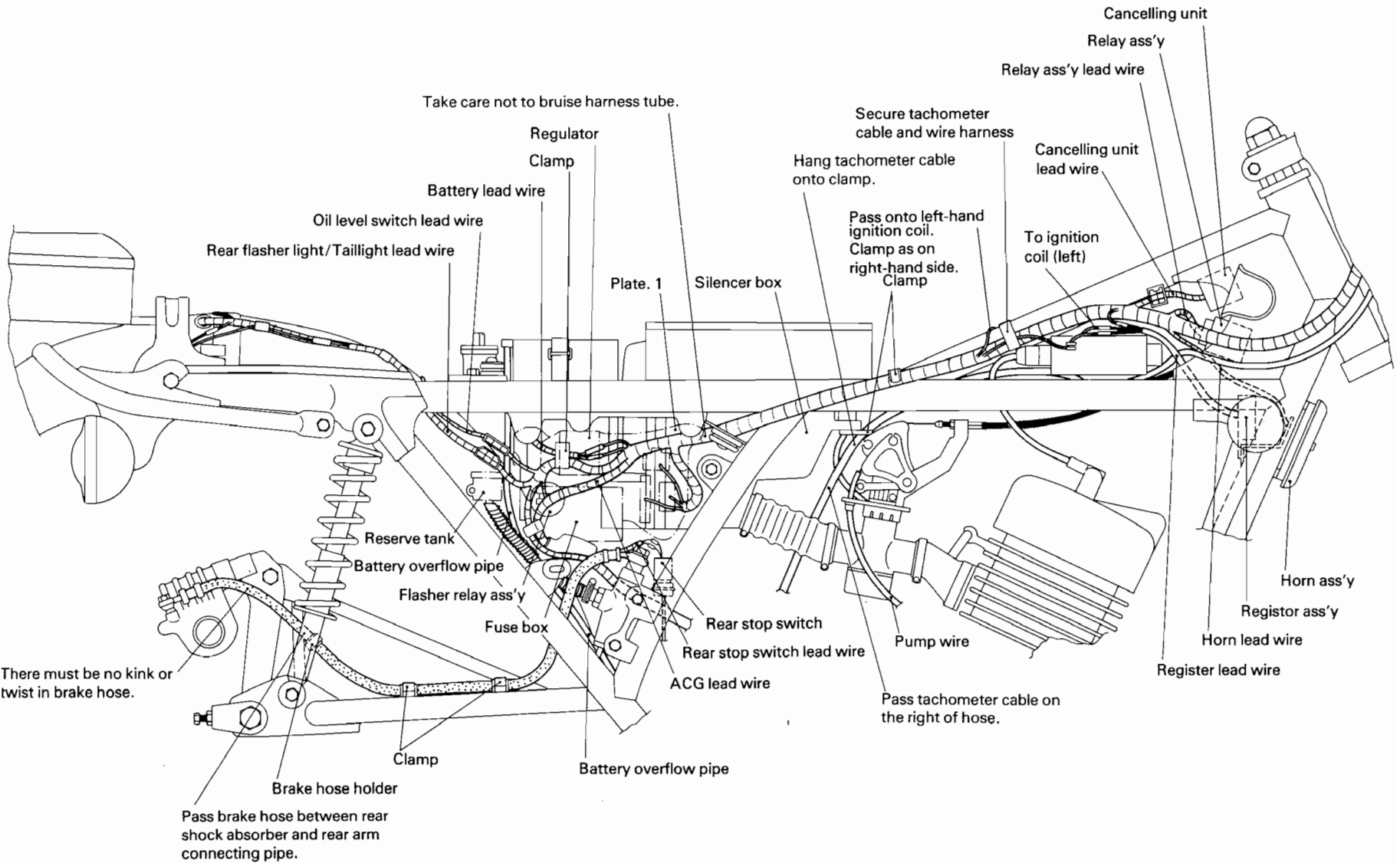

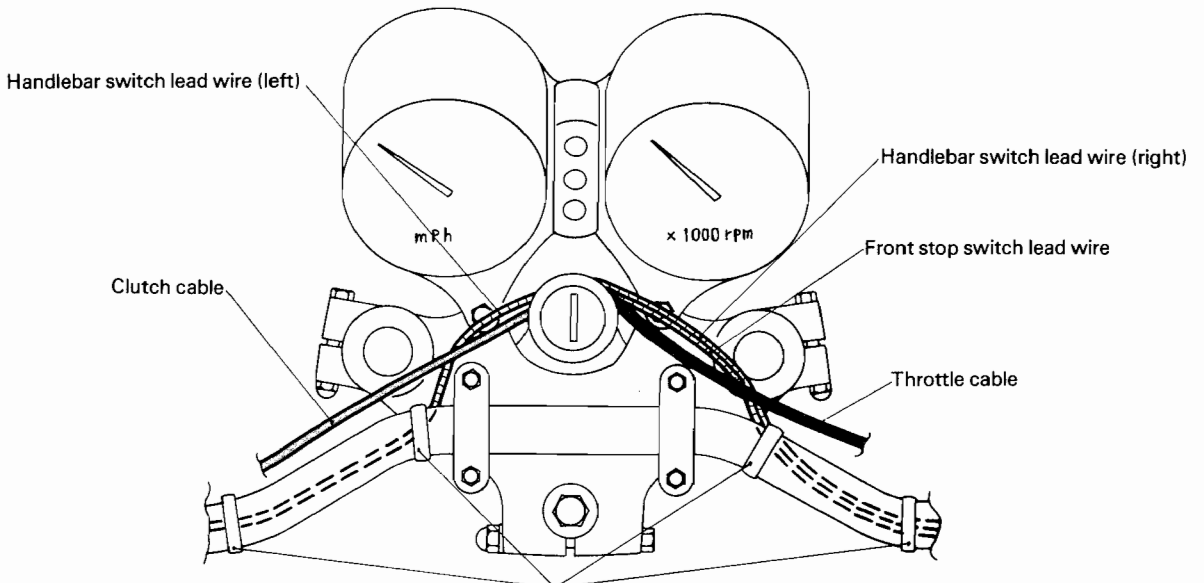
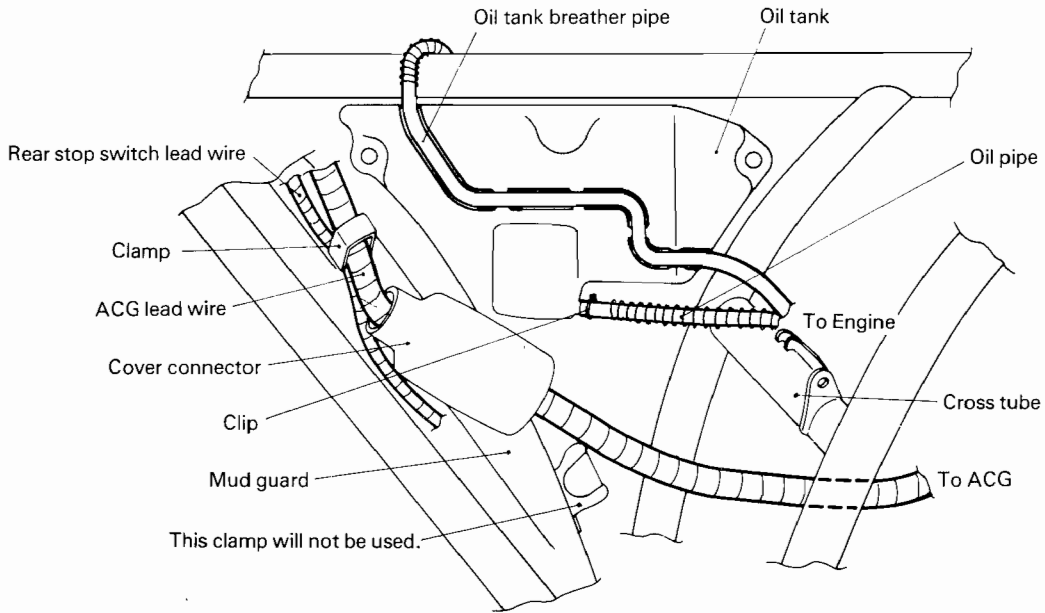

Pass these lead wires between handle crown and meter bracket. These wires must not be slack. Any slack must be stored under meters.

Secure handlebar switch lead wires to handlebar at four places using band meters

